

1995 STANDARD FOR PROTECTIVE HEADGEAR

1998 revision

For Use in Bicycling



The Snell Memorial Foundation Incorporated, as a Not-For-Profit organization under IRS section 501(C)(3), has registered in its Articles of Incorporation with the State of California the following purpose:

The Purposes of this Foundation are solely and exclusively scientific, educational and charitable and specifically to aid, help, promote and insure the life, safety, well-being and comfort of persons participating in or about any type of travel or vehicular transportation; to investigate, develop, approve and publicize any and all articles which may possibly relate thereto; to engage in research related to such articles directly or to finance such research and take any other action related directly or indirectly thereto, not for profit, but exclusively for scientific, educational and charitable purposes.

Directors

William C. Chilcott, Ph.D.

Channing L. Ewing, M.D.

Harold A. Fenner, Jr., M.D., President

Richard G. Snyder, Ph.D.

Daniel J. Thomas, M.D.

Members

Harry S. Philo, Esq.

Paul Appel, Esq.

Edward B. Becker, Executive Director

1995
STANDARD
FOR PROTECTIVE
HEADGEAR

1998 revision

For Use in Bicycling

Snell Memorial Foundation, Inc.
3628 Madison Avenue, Suite 11
North Highlands, CA 95660

**1995 STANDARD FOR PROTECTIVE
HEADGEAR**

For Use With Bicycles

Special Note to Helmet Users

There are four reasons for you to be interested in this Standard:

1. Bicycling imposes risks of death or permanent impairment due to head injury.
2. The proper use of protective helmets can minimize the risk of death or permanent impairment.
3. The protective capacity of a helmet is difficult to measure, particularly at the time of purchase or use.
4. Snell certification backed by ongoing random sample testing identifies those helmet models providing and maintaining the highest levels of head protection.

There are at least four critical elements affecting a helmet's protective properties:

1. Impact management - how well the helmet protects against collisions with large objects.
2. Helmet positional stability - whether the helmet will be in place, on the head, when it's needed.
3. Retention system strength - whether the chin straps are sufficiently strong to hold the helmet throughout a head impact.
4. Extent of Protection - the area of the head protected by the helmet.

This Standard describes simple tests for all four of these items. However, the tests for the second item, helmet stability, of necessity presume that the helmet is well matched to the wearer's head and that it has been carefully adjusted to obtain the best fit possible. Unless you take similar care in the selection and fitting of your own helmet, you may not obtain the level of protection that current headgear can provide.

The Foundation recommends the simple, straightforward procedure recommended to consumers by most helmet manufacturers:

Position the helmet on your head so that it sits low on your forehead; if you can't see the edge of the brim at the extreme upper range of your vision, the helmet is probably out of place. Adjust the chinstraps so that, when buckled, they hold the helmet firmly in place. This positioning and adjusting should be repeated to obtain the very best result possible. The procedure initially may be time consuming. Take the time.

Try to remove the helmet without undoing the chin strap. If the helmet comes off or shifts over your eyes, readjust and try again. If no adjustment seems to work, this helmet is not for you; try another.

This procedure is also the basis of the test for helmet stability described in this Standard. This test performs the same steps but uses standard headforms.

However, you must still perform this procedure for yourself when buying a helmet and every time you wear a helmet. Only in this way will you be able to make all the proper adjustments in pads and strapping to get the best fit possible. Furthermore, your test on your own head will be an improvement on ours; you will determine whether the helmet is appropriate for you personally.

There are several other important aspects of helmets to consider. Helmets for toddlers and young children are held to different performance requirements than helmets for adults and older children. Also, full face helmet configurations generally must meet all requirements set for other helmets plus an additional test of its full face component. Special care must be taken to ensure that the helmet you select is appropriate to the age of the wearer and is of the desired full or open face configuration.

The United States Consumer Product Safety Commission (CPSC) has established separate requirements for bicycle helmets intended for persons age 1 and older, and for persons age 5 and older. Helmets for children between the ages of one and five years must cover more of the wearer's head than helmets intended for persons

age five and older. Helmets meeting this 1998 revision of the 1995 Standard for protective headgear for use in bicycling will also meet all CPSC performance requirements for adults and older children but may not provide the extended coverage CPSC requires for those under five years.

Therefore, the Snell Memorial Foundation has prepared an addendum to this standard titled Child Helmet Addendum to the 1995 Standards for Protective Headgear for Children Age One Through Four Years For Use in Bicycling. Helmets meeting this as modified by the addendum will also meet all CPSC performance requirements for toddlers and younger children, and will be denoted as certified to B-95C.

Full face helmets provide an additional measure of protection from facial injuries. The external shell of these helmets includes a rigid "chin" bar that passes from left to right over the lower part of the face. The Foundation has devised special tests for the chin bars of full face helmets. However, the presence of a chin bar may not assure full facial protection. Some helmets come with a separate structure that bolts to the helmet in order to cover the lower part of the face. These removable chin bars are often intended to deflect debris and may not be effective facial protection in falls and accidents. The Foundation does not test removable chin bars and considers any headgear equipped with them to be an open face helmet.

FOREWORD

In a bicycle accident, the rider may suffer injury or death ¹. Helmets on the market today offer varying degrees of protection, but the consumer has little basis for judging the relative effectiveness of a given model. This Standard presents a rational means for differentiating between helmets which meet specified standards for impact protection and retention system effectiveness and those which do not.

¹Baker, Susan P., et al., Injuries to Bicyclists: A National Perspective (Baltimore: Johns Hopkins University Injury Prevention Center, 1993).

The Snell Foundation urges that protective helmets be required for all individuals participating in supervised racing events and encourages the general public to wear helmets which meet appropriate performance standards².

This 1995 Standard establishes performance characteristics suitable for bicycling. **This Standard does not establish construction and material specifications. The Foundation does not recommend specific materials or designs.** Manufacturers submit helmets to be tested under this Standard and if the submitted helmets pass, a certification is issued.

The Foundation will make available the identity of those products which have been Snell certified but will not attempt to rank those products according to performance or to any other criteria. Neither does the Foundation distinguish between the needs of participants in competitive bicycling events and those of the general public.

All of the requirements described herein, including both initial certification and random sample testing, are an integral part of this Standard. No helmet can satisfy the Standard unless it is subject to both certification and random sample testing by the Foundation.

Snell certification for protective headgear requires a specific contractual agreement between the primary headgear manufacturer and the Foundation. Certification procedures may be obtained upon application to the Foundation.

SNELL MEMORIAL FOUNDATION is a registered certification mark and B-95, B-95A and B-95C are certification marks of the Snell Memorial Foundation.

²The Foundation has published Standards for headgear used in bicycling, non-motorized sports, motorcycling, automobile racing, karting, competitive skiing, skiing and snowboarding and in equestrian activities. Copies of these Standards are available on request.

INTRODUCTION

This Standard addresses the problem of protecting the head from direct impact with various shapes of surfaces that may be encountered in a bicycling accident. The Standard prescribes direct measures of several factors bearing on a helmet's ability to protect the head as well as its general serviceability as bicyclist headgear. Thus, this Standard is directed towards the kinds of performance bearing on head protection that may not readily be discernible by even knowledgeable consumers at the time of purchase.

Some of these performance requirements have been expressed in terms of limitations on the various components and features of the single general helmet configuration currently available. These expressions have been used only for the sake of clarity and should not be misinterpreted as requiring specific configurations or materials. As newer helmet technologies appear, these limitations will be re-examined and, perhaps, restated.

A bicycle helmet consists generally of a rigid head covering and a retention system composed of flexible straps and hardware. The rigid covering protects the head from direct impact by its capacity to manage impact energy and also by its capacity to spread a concentrated load at its outer surface over a larger area of the wearer's head.

The retention system holds the headgear in position throughout normal usage and especially during falls and accidents. This Standard applies two different tests to the retention system. The first of these tests for stability by fitting the headgear to a standard headform and then attempting to displace it by applying tangential shock loadings. The second tests retention system strength by applying a shock load to the system components through a simulated chin.

The quality of the fit and the care taken with the adjustments are absolutely critical elements in these tests. **The manufacturer must provide suitable guidance so that the wearer will be able to select and adjust headgear to obtain the necessary quality of fit and positional stability.**

The capacity for impact protection is determined by direct measurement of the shock delivered through the helmet to a headform when the helmeted headform is dropped in a specified manner onto any of three unyielding anvils.

Most bicycle helmets are intended to accommodate a range of head sizes and shapes. Various thicknesses of resilient padding may be placed within otherwise identical helmets to configure the fit to several different ranges of head size. This resilient padding does not significantly affect the way the helmet absorbs and attenuates impact and is not directly addressed in this Standard.

Full face helmets provide a measure of facial protection in addition to the impact protection generally sought. The principle feature of a full face helmet is a chin bar that extends forward to cover the jaw area converting the facial opening into a visual port.

In order to be considered a full face helmet, the chin bar must be an integral part of the helmet structure. The Standard then tests the rigidity of the chin bar by dropping a weight onto it at a specified velocity so as to attempt to force the chin bar toward the interior of the helmet. The chin bar must not deflect more than a specified amount.

Other general features of bicycle helmets may include eye shades, bright colors and reflective surfaces. These features all deal with matters of safety and comfort that are not directly addressed in this Standard but which merit the consideration of wearers as well as manufacturers.

Although bicycle helmet use has been shown to reduce head injuries significantly, there are limits to a helmet's protective capability. No helmet can protect the wearer against all foreseeable accidents. Therefore, injury, death or permanent impairment may occur in accidents which exceed the protective capability of any helmet including even those helmets meeting the requirements of this Standard.

A helmet's protective capability may be exhausted in an accident. Helmets are constructed so that the energy of a blow is managed by the helmet, which may cause its partial or total destruction. Because the damage may not be readily apparent, the Foundation strongly recommends that a helmet impacted in an accident be returned to the

manufacturer for complete inspection. If it is not possible to do so, the helmet should always be destroyed and replaced.

Finally, the protective capability may diminish over time. Some helmets are made of materials which deteriorate with age and therefore have a limited life span. At the present time, the Foundation recommends that bicycle helmets be replaced after five (5) years, or less if the manufacturer so recommends.

CONSTRUCTION

A. General

The assembled helmet shall have smooth external and internal surfaces. Any feature projecting more than 5 mm beyond the outer surface must readily break away; all other projections on the outer surface shall be smoothly faired and offer minimal frictional resistance to tangential impact forces. There shall be no fixture on the inner surface projecting more than 2 mm into the helmet interior. The helmet shall provide as nearly uniform impact protection over the entire protected area as is practicable.

If the absence of any detachable component of the helmet does not prevent its being worn, then this absence must not compromise either the retention system or the impact protection. If any part of the helmet detaches during testing, it must offer no laceration or puncture hazard nor reduce the area of coverage of the head.

If the manufacturer provides add-ons such as visors, face shields and neck curtains with the helmet, these add-ons must neither lessen the protective capability of the basic helmet nor create a direct hazard for the wearer.

B. Materials

Ideally, materials used in the manufacture of the helmet should be of durable quality and not be harmed by exposure to sun, rain, dust, vibration, sweat or products applied to the skin or hair. Similarly, the materials should not degrade due to temperature extremes likely to be encountered in routine storage or transportation.

Materials which are known to cause skin irritation or are conducive to disease shall not be used for the parts which contact the skin. Materials that support the growth of fungi or algae shall not be

used. Padding or lining materials, if used, may be detachable for the purpose of washing.

C. Finish

All edges of the helmet shall be smoothed and rounded with no metallic parts or other rigid projections on the inside of the shell that might injure the wearer's head in the event of impact.

D. Retention System

The retention system shall be designed so as to discourage misuse. That is, of all the ways in which the retention system might be used, the design use shall be the simplest and quickest to implement. Helmets shall not be fitted with "non-essential" features which, if misused, can degrade the performance. Quick release buckles, if used, shall not be able to be released inadvertently.

E. Peripheral Vision

The helmet shall provide peripheral visual clearance. This clearance is defined using a reference headform appropriate to the size of the helmet and corresponds to a visual field of at least 110 ° to the right and to the left of straight ahead.

The helmet shall also provide an upward visual clearance. This clearance is defined using a reference headform appropriate to the size of the helmet and corresponds to a visual field of at least 25 ° upward from horizontal.

QUALIFICATIONS FOR CERTIFICATION

For qualification testing, helmets shall be in the same condition as those offered for sale. No helmet or component which has been subjected to any tests described in this Standard shall be offered for sale after testing. A total of six (6) complete helmets must be submitted by the manufacturer for a certification test program for each size of this model offered for sale. Five of these samples will be destroyed in testing; the sixth shall be retained for comparison and reference.

MODIFICATIONS

Cosmetic changes to certified headgear are permissible. Such changes are generally limited to marking or trimming the headgear with manufacturer approved paint or tape.

Otherwise, modification of certified headgear creates new headgear which will not have the confidence and certification of the Foundation until samples have been submitted and evaluated. Manufacturers must not place the Foundation's certification label in any modified headgear for which they have not received written permission.

After-market modifiers of such certified headgear should be aware that any structural modification may adversely affect a helmet's protective capability and therefore invalidate the certification.

RANDOM SAMPLE TESTING

In addition to the certification testing, the Foundation will routinely obtain and test samples of previously certified models. These samples will be selected from among those stocks intended for retail sale to consumers. In this manner, the Foundation will attempt to ensure that the helmets made available to the public continue to meet the performance requirements of this Standard.

In cases where helmets are provided directly to users and do not pass through a normal sales distribution system, the Foundation will set up alternative procedures to monitor certified products. Specifically, if helmets are provided directly to teams or individuals for use in organized events, the Foundation must have access to the helmets for spot checking and non-destructive evaluation.

LABELING AND MARKING

Each helmet shall have durable, visible and legible labeling identifying the manufacturer, the month and year of manufacture, the model and the size. Labeling shall be uncoded and either in English

or a language common to the area where the helmets are to be distributed. The headgear shall also be labeled to the following effect:

1. Certified for bicycle use only.
2. No helmet can protect the wearer against all foreseeable impacts. However, for maximum protection, the helmet must be of good fit and all retention straps must be securely fastened to retain the helmet. The helmet, when fitted and fastened, shall not be removed easily.
3. This helmet is so constructed that the energy of an impact may be absorbed through its partial destruction, though damage may not be visible. If it suffers an impact, it must either be returned to the manufacturer for inspection or be destroyed and replaced.

If any of the helmet components are sensitive to common solvents, adhesives, paints or cleansers; the helmet must also bear labels to the following effect:

This helmet can be seriously damaged by some common substances without visible damage. Apply only the following: (Recommended cleaning agents, paints, adhesives and the like) as appropriate.

These items must be preceded by the signal word "WARNING" or, if the items are not expressed in English, the most appropriate translation of "WARNING." Only a single signal word is required if more than one of these items are included on a single label but each label containing any of these items must include the signal word. The signal word shall be all in capital letters, bold print, and a type size equal to or greater than the other text on the label.

Each helmet shall also include one of the Foundation's serialized certification labels. The Snell certification label shall be placed either inside or on the outside of the helmet, as appropriate, in such a way that it cannot be removed intact.

The registered trademark (certification label) of the Snell Memorial Foundation may be used by the manufacturer only under license from the Snell Memorial Foundation.

EXTENT OF PROTECTION

The extent of protection corresponds to that region of the head for which protection is sought. This region is defined according to the geometry of four reference headforms: 'A', 'E', 'J', 'M' and 'O' which are described in International Standards Organization (ISO) Draft Standard ISO DIS 6220-1983.

There are a number of planes fixed in the geometry of these headforms as shown in figure 1. This description of the extent of protection uses the ISO definitions of the basic plane, the longitudinal plane, the transverse plane and the reference plane as well as several other planes which have been defined strictly for convenience and clarity.

The basic plane corresponds to the anatomical plane (Frankfort plane) that includes the auditory meatuses and the inferior orbital rims. The longitudinal or mid-sagittal plane is perpendicular to the basic plane and is the plane of symmetry dividing the right half of the headform from the left. The transverse or coronal plane is perpendicular to both the longitudinal and basic planes. It corresponds to the anatomical plane that contains the two auditory meatuses and divides the front from the rear portions of the head. The reference plane is parallel to the basic plane and lies above it at a distance determined by the size of the headform: 24 mm, 26 mm, 27.5 mm, 29.0 mm and 30 mm for the 'A' through 'O' headforms respectively.

These four planes are all well known entities. The remaining planes, however, have been defined purely for the purposes of this Standard. The S_0 plane is parallel to the basic plane and lies above it at a distance determined by the size of the headform: 46.8 mm, 50 mm, 53 mm, 55.2 mm and 57.2 mm for the 'A' through 'O' headforms respectively.

The S_1 plane is parallel to the S_0 plane and the basic plane and lies between them at a distance of 17.4 mm, 18.8 mm, 20 mm, 21 mm and 21.7 mm below the S_0 plane for the 'A' through 'O' headforms respectively. The S_2 plane is parallel to the S_0 plane and lies below it at a distance of 34.8 mm, 37.6 mm, 40 mm, 42 mm and 43.5 mm for the 'A' through 'O' headforms respectively. The S_4 plane

is also parallel to the S_0 plane and lies below it at a distance of 52.2 mm, 56.4 mm, 60 mm, 63 mm and 64.5 mm for the 'A' through 'O' headforms respectively.

The fore plane is parallel to the transverse plane. It lies behind the point where the reference plane and longitudinal planes intersect with the front surface of the headform. The distance from this point, hereafter called the reference point, is determined by the size of the headform: 39 mm, 42.2 mm, 45.2 mm, 47.4 mm and 49.2 mm for the 'A' through 'O' headforms respectively.

The rear plane divides the rear third of the head from the front two thirds. It is parallel to the transverse plane and lies at a given distance behind the reference point. This distance is determined by the size of the headform: 128.6 mm, 139 mm, 148.4 mm, 155.8 mm and 161.5 mm for the 'A' through 'O' headforms respectively.

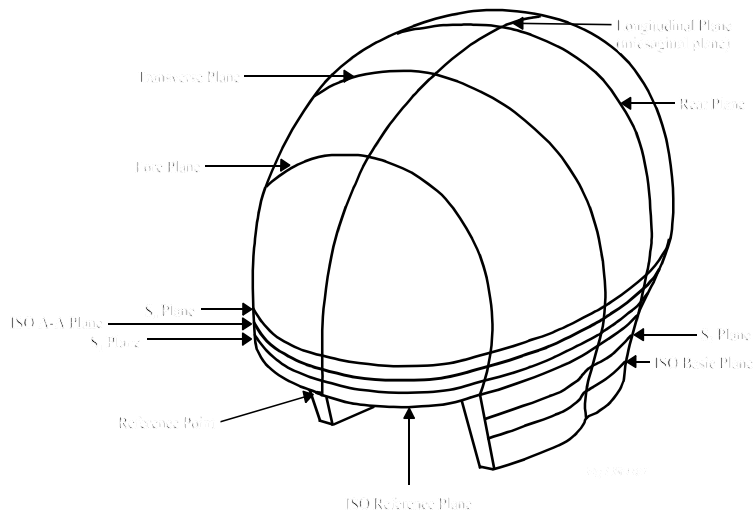

ISO DIS ---- 6220-1983

figure 1. - Planes in the ISO Headform

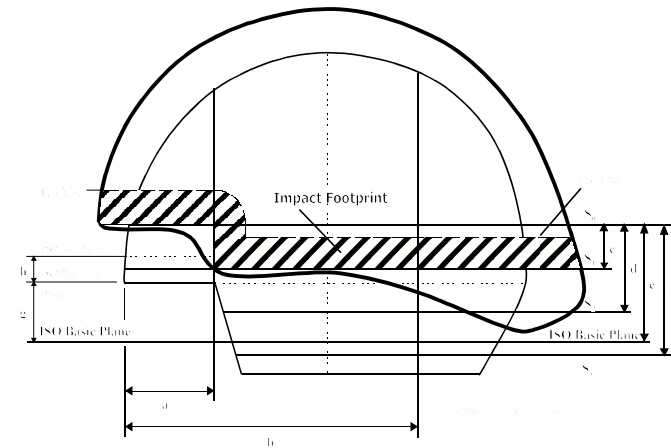

figure 2. - The Extent of Protection

Headform	a	b	c	d	e	f	g	h
ISO A	39.0	128.6	17.4	34.8	46.8	52.2	24.0	12.7
ISO E	42.2	139.0	18.8	37.6	50.0	56.4	26.0	12.7
ISO J	45.2	148.4	20.0	40.0	53.0	60.0	27.5	12.7
ISO M	47.4	155.8	21.0	42.0	55.2	63.0	29.0	12.7
ISO O	49.2	161.5	21.7	43.5	57.2	64.5	30.0	12.7

Measurements are in mm's

The extent of protection provided by the helmet includes the entire region above the S_0 plane and forward of the fore plane, and the entire region above the S_1 plane and behind the fore plane (See Figure 2) however, refer to section C under Testing entitled Marking, to determine specific requirements.

TESTING

A. Helmet Positioning

Each helmet will be positioned on the appropriate headforms for testing according to the helmet positioning indices specified. If the manufacturer fails to provide positioning information with certification samples, the helmets will be positioned according to the best judgement of the Foundation's technical personnel. If the helmets meet certification requirements, the helmet positioning indices will be those used in all future testing.

These helmet positioning indices represent distances on the headform measured from the basic plane along the intersection with the longitudinal plane to the lower edge of the helmet or the upper edge of the helmet face port as appropriate.

Helmet positioning indices will be assigned for all headform sizes appropriate to the headgear. Each headgear could conceivably require five helmet positioning indices, one each for the 'A', 'E', 'J', 'M' and 'O' headforms.

B. Inspection

Each helmet will be inspected for the required labels and for compliance with the general limitations made on structure. The weight and various circumferences will be recorded for comparison with other samples of the same make and model.

Some helmets may incorporate innovations and other features not anticipated by this Standard but which raise concerns about the safety and effectiveness of the headgear. These will be referred to members of the Foundation's Board of Directors for evaluation. Any feature found to reduce the protective capacity of the headgear, whether explicitly mentioned in this Standard or not, will be a cause for rejection.

C. Marking

The helmet is positioned upon the largest appropriate ISO headform and held in place with an applied force of 50 newtons (11.25 lbs). The intersections of the shell with the various defined planes are then traced onto the outer surface of the helmet as described below.

The level of the S_0 plane is marked on that portion of the helmet

in front of the fore plane. The level of the S_1 plane is marked on that portion lying behind the fore plane. Descending line segments along the fore plane are marked to join the S_0 and S_1 planes. These lines enclose a distinct area of the helmet and define the boundary of the extent of protection.

If any part of the S_0 plane falls below the edge of the helmet, the helmet shall be rejected. The helmet may be designed so that parts of these descending line segments and portions of the extent of protection between the fore and rear planes fall outside the edges of the helmet; this shall not be a cause for rejection. Finally, except for a region of 15 mm on both sides of the longitudinal plane, if any part of the S_1 plane behind the rear plane falls below the edge of the helmet, the helmet shall be rejected. In areas where the helmet need not meet the boundary of the extent of protection, if in the test technician's judgement, there is insufficient material in the helmet below the test line to withstand impact testing without endangering the test equipment, the helmet may be rejected at this point in the procedures.

A test line shall be drawn within this extent of protection so that it is 15 mm from the closest point on the boundary (See figure 2). If the extent of protection lies below the edge of the helmet, the test line will be drawn 15 mm from an imaginary boundary inferred from a best approximation to a continuation of the helmet's external surface.

If identical helmets are to be configured with different thicknesses of comfort padding to accommodate different ranges of head size, the extent of protection marked on the test samples shall include the extent of protection for each different configuration as marked on the largest headform appropriate for each. That is: the helmet must meet all the requirements of this Standard in each of the intended configurations.

D. Peripheral Vision

The clearance for peripheral vision will be checked by placing the helmet on each appropriate ISO headform, positioning it according to the apposite helmet positioning index and holding it in place with a force of 50 newtons. The clearance must include the following solid angles to the front of the headform:

1. The upward visual clearance.
2. The lateral visual clearance.
3. The downward visual clearance except for the breath deflector allowance.

The upward visual clearance is the solid angle bounded by the reference plane of the headform and a second plane tilted 25° up from the reference plane. This second plane intersects the reference plane at two points on the front surface of the headform that are 31 mm to the right and left of the longitudinal plane as shown in figure 3.

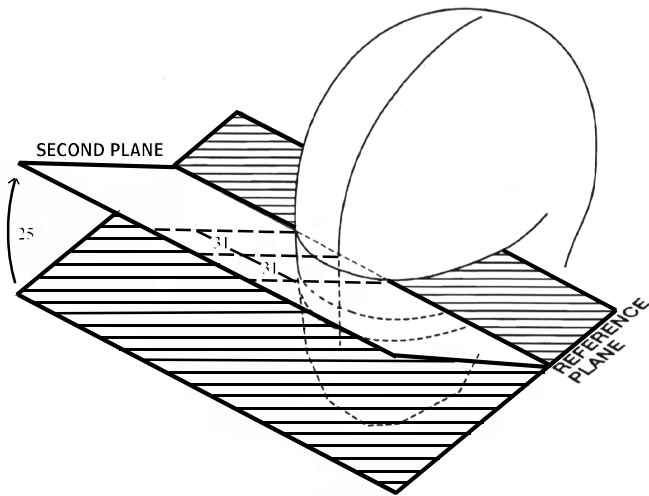

figure 3. Upward Visual Clearance

The lateral visual clearance, as shown in figure 4, is the solid angle bounded by the reference plane, the S_4 plane and two more planes that are perpendicular to the reference plane and that contain the reference point. One of these two planes forms an angle of 110° with the longitudinal plane and lies to the left of the headform. The other forms the same angle to the right of the headform.

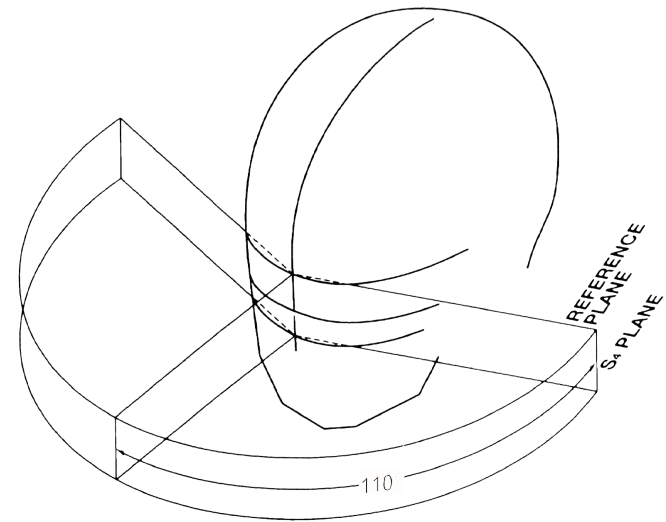

figure 4. - Lateral Visual Clearance

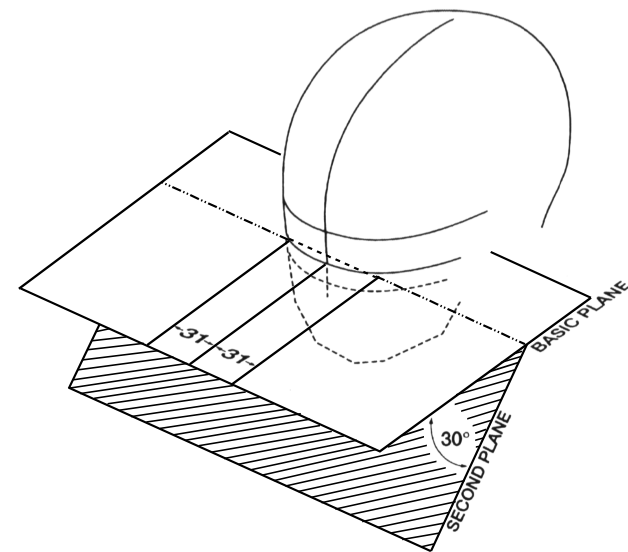

figure 5. - Downward Visual Clearance

The downward visual clearance is the solid angle bounded by the basic plane of the headform and a second plane tilted 30° down from the basic plane that intersects it at two points on the front surface of the headform that are 31 mm to the right and left of the longitudinal plane as shown in figure 5. However, intrusions into this downward clearance are permitted so long as the intrusions are within the breath deflector allowance, as shown in figure 6.

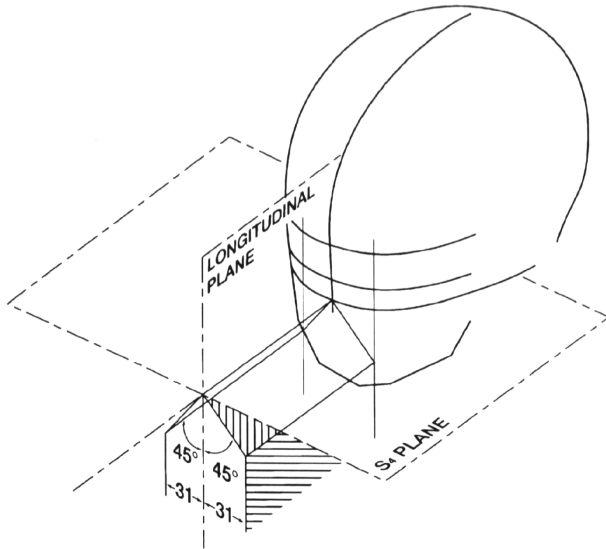

figure 6 .- Breath Deflector Allowance

The breath deflector allowance is shown in figure 6. It includes the region that is within 31 mm to the right and left of the longitudinal plane and that lies below the two planes that form 45° with the longitudinal plane and that intersect it at the level of the S₄ plane.

E. Performance Testing

The performance testing first subjects helmets to a dynamic test of retention system strength or to a test for positional stability. The helmets are then subjected to several impact management tests. These tests are conducted upon helmet samples either kept under

laboratory ambient temperature and humidity or that have been conditioned in one of three environments simulating some of the conditions in which the helmet might reasonably be expected to be used.

In certification testing, the first of the five samples is kept at laboratory ambient temperature and humidity and allowed to come to equilibrium. It is subjected to the positional stability test and then to the impact management tests. The second, third and fourth samples are conditioned hot, cold and wet, and a fifth sample is conditioned either hot, cold or wet according to the best judgement of the Foundation's technical personnel. The second through the fifth samples are subjected to the dynamic test of the retention system and then to the impact management tests.

In random sample testing, the sample may be at ambient temperature and humidity and subjected to either the test for positional stability or to the dynamic test of the retention system before being tested for impact management. Otherwise, the sample may be conditioned either hot, cold or wet and subjected to the dynamic test of the retention system before being tested for impact management.

E1. Conditioning for Testing

The barometric pressure for all conditioning and testing environments shall be 75 to 110 kPa. The laboratory temperature and relative humidity shall be within 17°C to 27°C and 20% to 80% respectively. All test samples shall be stabilized within these ambient conditions for at least four hours before further conditioning and testing.

a. Cold. The sample shall be conditioned by being exposed to a temperature of -20° C ± 2° C for a period of not less than four (4) hours, nor more than twenty-four (24) hours.

b. Heat. The sample shall be conditioned by being exposed to a temperature of 50° C ± 2° C for a period of not less than four (4) hours, nor more than twenty-four (24) hours.

c. Wet. The sample shall be immersed crown down in potable water at a temperature of 17°C to 27°C to a crown depth of 305 mm ± 25 mm for a period of not less than four (4) hours, nor more than twenty-four (24) hours.

All testing of these hot, cold and wet helmets shall begin within two (2) minutes from the time of removal from the conditioning apparatus. The samples shall be returned to the conditioning apparatus between tests.

E2. Positional Stability (Roll-Off)

The test for positional stability shall only be applied to samples kept at ambient laboratory temperature and humidity. The helmet shall not have been subjected to any prior performance testing.

The helmet shall be tested on the smallest appropriate standard full-face headform. The headform shall be supported on a stand so that its vertical axis points downward at an angle of 135° to the direction of gravity. The headform shall be oriented face down. The helmet shall be placed on the headform and adjusted to obtain the best configuration of the retention system. An inelastic strap shall be hooked to the edge of the helmet at the rear centerline and brought forward so that its free end hangs downward across the top of the helmet. An inertial hammer shall be suspended from the free end of the strap. This inertial hammer shall enable a 4.0 kg ± 50 g mass to be dropped through a 0.6 m guided fall in order to deliver an abrupt shock load to the headgear. The shock load will force the helmet to rotate forward on the headform. The helmet may be shifted but must remain on the headform.

The headform shall be repositioned so that it is facing upward but with the vertical axis still oriented downward at 135° to gravity. The helmet shall be positioned and adjusted to obtain the best configuration of the retention system. The inelastic strap/inertial hammer shall be hooked to the brow edge of the helmet at the centerline so that the rope lies along the centerline and hammer is suspended from the top of the helmet. The shock weight shall be dropped through the 0.6 m guided fall delivering an abrupt shock load forcing the helmet to rotate rearward. The helmet may be shifted but must remain on the headform.

The inertial hammer shall be such that its mass is no more than 5.0 kg including the 4.0 kg shock mass.

E3. Dynamic Test of Retention System

The dynamic test of the retention system may be applied to any sample either kept at ambient temperature and humidity or

conditioned hot, cold or wet. However, the sample shall not have been subjected to any prior performance testing.

The helmet shall be placed on a headform in such a manner that the chin strap may be fastened under a device whose upper end approximates the contour of the bony structure of the jaw. The device will then be given a mechanical pre-load followed by a dynamic loading. The retention system fails if it cannot support the mechanical loads or if the maximum deflection during the dynamic load exceeds 30 mm. The retention system also fails if it cannot be easily and quickly unfastened after testing.

a. This chinstrap loading device shall consist of a simulated jaw attached to an inertial hammer. The jaw portion shall consist of two freely spinning metal rollers mounted in a rigid frame. The rollers shall be each 12.7 mm ± 0.5 mm in diameter and separated by 76 mm ± 1 mm on center. The inertial hammer shall be suspended from the frame midway between the rollers and shall permit a mass of 4 kg to be dropped in a guided fall of at least 60 cm to a rigid stop such that the entire shock of the stop shall be delivered through the hammer and frame to the rollers. The mass of this device including the 4 kg drop weight shall be 11 kg ± 0.5 kg.

b. Once the helmet is on the headform and the chinstrap buckled under the rollers, the entire mass of the chinstrap loading device shall be suspended from the chinstrap for at least 60 seconds.

c. A baseline position for the device shall be marked and the 4 kg mass shall then be raised 60 cm and released to fall to the rigid stop. The peak dynamic deflection of the device from the baseline shall be recorded.

E4. Impact management Tests

The impact management tests may be performed on samples kept at ambient temperature and humidity or conditioned hot, cold or wet. Samples may be first subjected to either positional stability testing or the test for retention system strength.

These tests involve a series of controlled impacts in which the helmet is positioned on a test headform. The helmeted headform is then dropped in guided falls onto specified test anvils. The impact site and the impact energy must meet certain requirements in order for the tests to be valid. If in a valid test, the peak acceleration

imparted to the headform exceeds 300 G's, the helmet shall be rejected.

If the sample is so constructed that it interferes with the test equipment preventing impacts at sites within the test line, then, at the discretion of the Foundation's technical personnel, parts of the helmet may be cut away to facilitate testing. Every reasonable effort to minimize such cutting will be made. However, there shall be no relaxation of the impact levels or of the test criteria.

E4.1 Impact Management Test Equipment

The test equipment shall consist of at least the following items:

a. The smallest of the headforms appropriate for the helmet sample. This headform shall be of rigid, low resonance metal such as magnesium alloy and shall conform to the 'A', 'E', 'J', 'M' or 'O' geometries specified in ISO DIS 6220-1983.

b. A ball-arm/collar assembly which is fitted to a socket machined into the base of the headform. The ball/socket configuration shall be such that the geometrical center of the ball is located on the central vertical axis of the headform 12.7 mm above the reference plane as described in ISO DIS 6220-1983. The ball-arm/collar assembly shall also include a uniaxial accelerometer fixed firmly into the ball.

c. A headform support assembly rigidly attached to the ball-arm. This support assembly shall be such that it and consequently the headform may be guided in a vertical drop. The weight of the support assembly shall not exceed 25% of the combined weights of the headform, ball-arm, collar and accelerometer. The total mass of the headform/support assembly shall be $5.0 \text{ kg} \pm 0.1 \text{ kg}$.

d. A guidance system such that the headform/support assembly may be guided in vertical drop onto a test anvil. This guidance system may consist of two or more wires or one or more rails. The headform/support - guidance system - test anvil alignment shall be such that:

d1. The drop trajectory shall be a straight line within 3° of vertical and within 5° of the sensitive axis of the uniaxial accelerometer.

d2. The line parallel to the drop trajectory and passing through the center of the headform ball-socket shall pass within 5 mm of the

center of the test anvil, within 10 mm of the center of gravity of the headform/support assembly, and within 5 mm of the sensitive element of the uniaxial accelerometer.

e. A rigid anvil mount consisting of a solid mass of at least 135 kg. The upper surface of the anvil mount shall consist of a steel plate with a minimum thickness of 12 mm and a minimum surface area of 0.10 m^2 .

f. Three test anvils : flat, hemispherical and kerbstone.

f1. The flat anvil shall have a minimum surface area of 0.0127 m^2 , e.g. 127 mm diameter face. When fixed in position on the anvil mount, the surface shall be perpendicular to the headform trajectory.

f2. The hemispherical anvil shall have a $48 \text{ mm} \pm 0.5 \text{ mm}$ radius.

f3. The kerbstone shall have two faces with a dihedral angle of 105° , each face shall be oriented at approximately 52.5° to the vertical meeting along a striking edge with a radius of $15 \text{ mm} \pm 0.5 \text{ mm}$, the height shall be not less than 50 mm and the length not less than 200 mm. When in position, the striking edge shall be perpendicular to the headform trajectory.

g. A uniaxial accelerometer. The acceleration data channel must comply with SAE recommended practice J 211 requirements for channel class 1000 with the exception that the frequency response need not include the range from dc to 10 Hz which may not be obtainable using certain types of transducers.

h. A velocity measurement device which will yield the velocity of the headform/support assembly within the last 40 mm of travel before impact. The velocity measurements must be accurate to within $\pm 1\%$.

E4.2 Test Definitions

a. The impact site refers to the portion of the helmet struck during an impact test. It is defined as the point where a line passing through the center of the headform ball and the center of the anvil intersects the outer surface of the helmet at the instant the helmet first touches the anvil.

b. The impact energy is the kinetic energy of the headform/support assembly at the instant of impact. It is defined as the mass of the headform/support assembly times the square of the

velocity measurement times one half. The mass of the helmet is ignored in this calculation.

E4.3 Test Impacts

Each sample will be subjected to no more than four test impacts. Test impact sites shall be on or above the test line. Rivets, vents and any other helmet feature within this region shall be valid test sites. Similarly, no allowance shall be made for the cut of the helmet either between the fore and rear planes or at the rear centerline; no matter how closely the edge of the helmet encroaches on the test line. However, if a test impact is sited closer than 120 mm to any previous test impact site on that sample, that impact shall be declared invalid.

There is no restriction regarding test anvil selection except that each anvil shall be used at least once for each helmet sample tested. The impact energies for each test impact are as follows:

a. For each impact against the flat anvil, the impact energy shall be 110 J for certification testing and 100 J for all other testing regardless of headform size or weight. Given an ideal frictionless mechanical test facility, this impact energy represents a 2.2+ meter drop of a 5 kg headform and supporting assembly.

b. For each impact against the hemispherical anvil, the impact energy shall be 72 J for certification testing and 65 J for all other testing regardless of headform size or weight. Given an ideal frictionless mechanical test facility, this impact energy represents a 1.3+ meter drop of a 5 kg headform and supporting assembly.

c. For each impact against the kerbstone anvil, the impact energy shall be 72 J for certification testing and 65 J for all other testing regardless of headform size or weight. Given an ideal frictionless mechanical test facility, this impact energy represents a 1.3+ meter drop of a 5 kg headform and supporting assembly.

d. If the impact energy for any test impact exceeds the energy specified by more than 3%, that impact shall be declared invalid.

Please Note: The impacts described above are based on specific energies and not prescribed drop heights. To attain the proper energy for an impact, it is likely that the drop height will need to be adjusted to compensate for frictions inherent in most mechanical helmet testing systems. Height adjustments for these frictions should not account for more than 10% of the total drop height.

E4.4 Impact Test Interpretation

The peak acceleration of the headform shall not exceed 300 G's for any valid test impact. Similarly, the helmet's protective structures shall remain intact throughout the testing. If the Foundation's technical personnel conclude that the headgear has been compromised by breakage, the sample shall be rejected.

If, in certification testing, a sample is found to meet all the test criteria but any two of the impacts were at less than 97% of the impact energy specified, the testing for that sample shall be declared inconclusive and must be repeated. Also, if an invalid impact produces a peak acceleration exceeding 300 G's, the testing for the sample shall be declared inconclusive and must be repeated.

The impact test procedures leave considerable latitude to the helmet tester regarding site and anvil selection. It is expected the tester will orchestrate each test series in order to investigate potential weaknesses and to exercise each likely failure mode.

If at the end of a certification test series, the Foundation's technical personnel conclude that the results obtained in valid impacts are not sufficient to determine whether the helmet model meets the performance requirements of this standard, additional samples may be conditioned and tested. It is expected that all samples submitted will meet all the test requirements.

E5. Chin Bar Test

The chin bar test applies to full face helmets only. At least one helmet in each certification series shall be tested. The helmet shall be firmly mounted on a rigid base so that the chin bar faces up and the reference plane is at $65^\circ \pm 5^\circ$ from horizontal. A mass of 5 kg \pm .2 kg with a flat striking face of 0.01 m² minimum area shall be dropped in a guided fall so as to strike the central portion of the chin bar with an impact velocity of 2.8 m/sec \pm 0.2 m/sec. The maximum downward deflection of the chin bar must not exceed 60 mm nor any component fail so as to cause a potential injury to the wearer.

CHILD HELMET ADDENDUM TO THE 1995 STANDARDS FOR PROTECTIVE HEADGEAR

For Children Age One Through Four Years
For Use in Bicycling

FOREWORD

This addendum applies to two different helmet standards promulgated by the Snell Memorial Foundation:

1. The 1998 Augmentation to the 1990 Standard for Protective Headgear for Use in Bicycling. (B-90)
2. The 1995 Standard for Protective Headgear for Use in Bicycling. (B-95)

Helmets that meet the requirements of the B-90, or the B-95 base standards as modified by this addendum may be designated as certified to either B-90C or B-95C respectively.

This addendum incorporates into the Snell bicycle helmet standards the special provisions set by United States Consumer Product Safety Commission for helmets intended for use by children ages one through four inclusive. Young children's helmets meeting the requirements of the base standards as modified by this addendum will therefore also meet the performance requirements set by CPSC.

INTRODUCTION

The CPSC standard for bicycle helmets establishes performance requirements for two categories of helmet: helmets intended for persons older than one year, and helmets intended for persons older than five years. The first category applies to young children and the second to older children and adults.

The only difference in the CPSC requirements for these two categories is in head coverage. The helmets intended for young children are subject to impact testing over a greater area of their surface. The essence of this difference is that these helmets must provide all the protection demanded of helmets intended for adults and, in addition, must also protect their wearers from impacts falling lower on the brow, sides and back of the head.

Therefore, this addendum describes an extent of protection and test line satisfying CPSC requirements for children's helmets. The impact test requirements of the base standards apply to the entire portion of the helmet on or above this redefined test line.

However, the extended coverage may conflict with visual field requirements of the base standards. Therefore, this addendum replaces the visual field requirements of the base standard with new requirements specific to helmets for young children and toddlers and which satisfy those requirements set by CPSC.

Unless specifically waived, all other requirements set in the base standards will continue to apply as before.

EXTENT OF PROTECTION

The extent of protection corresponds to that region of the head for which protection is sought. This region is defined according to the geometry of two reference headforms: 'A' and 'E' which are described in International Standards Organization (ISO) Draft Standard ISO DIS 6220-1983.

This addendum describes a number of planes and points fixed in the geometry of these ISO headforms. Some of these have been taken directly from the ISO DIS 6220-1983. The basic plane corresponds to the anatomical plane (Frankfort plane) that includes the auditory meatuses and the inferior orbital rims. The longitudinal or midsagittal plane is perpendicular to the basic plane and is the plane of symmetry dividing the right half of the headform from the left. The transverse or coronal plane is perpendicular to both the longitudinal and basic planes. It corresponds to the anatomical plane that contains the two auditory meatuses and divides the front from the rear portions of the head. The reference plane is parallel to the basic plane and lies above it at a distance determined by the size of the headform: 24 mm and 26 mm for the 'A' and 'E' headforms respectively.

The following entities have been defined purely for the purposes of this Standard. The reference point is the point on the front of the headform at which the reference and longitudinal planes intersect. The CC_0 plane is parallel to the reference plane and lies above it at a distance determined by the size of the headform: 15 mm and 17 mm

for the 'A' and 'E' headforms respectively.

The CC_1 plane is parallel to the reference plane and lies below it at a distance of 3 mm regardless of headform size. The CC_2 plane is parallel to the reference plane and lies below it at a distance of 30 mm and 32 mm for the 'A' and 'E' headforms respectively.

The CC_3 plane divides the front of the head from the middle and rear portions. It is parallel to the transverse plane and lies behind the reference point at a distance of 48 mm and 52 mm for the 'A' and 'E' headforms respectively. The CC_4 plane divides the back of the head from the front and middle portions. It is parallel to the transverse plane and lies behind the reference point at a distance of 103 mm and 111 mm for the 'A' and 'E' headforms respectively.

The extent of protection provided by the helmet must include the entire region above the CC_0 plane and forward of the CC_3 plane, the entire region above the CC_1 plane and between the CC_3 and CC_4 planes, and, finally, the entire region above the CC_2 plane and behind the CC_4 plane. (See figure 1a.)

HELMET MARKING

The requirements and procedures for helmet marking set in the two base standards do not apply to helmets intended for children less than five years of age. Instead, the helmet shall be placed on 'E' headform, or, if the helmet is too small for an appropriate fit, on the ISO 'A'.

The helmet shall be held in place by an applied force of fifty newtons (11.25 lbs) and its positioned adjusted according to the manufacturer's specified helmet positioning index (HPI). If the manufacturer has failed to provide HPI information, the helmets will be positioned according to the technician's best judgement. If the helmets meet certification requirements, those positioning indices will be used in all future testing.

Once the helmet is properly positioned, the intersections of the helmet's exterior surface with the various headform planes will be traced onto the helmet in the following manner. The level of the CC_0 plane is marked on that portion of the helmet in front of the CC_3

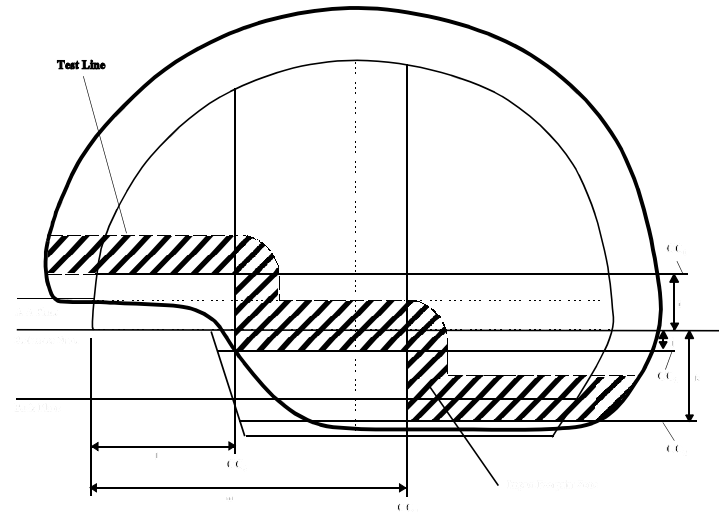

Figure 1a - Extent of Protection Child Helmet

Headform	i	j	k	l	m
ISO A	15	3	30	48	103
ISO E	17	3	32	52	111

Units are in millimeters.

plane. The level of the CC_1 plane is marked on both sides of the helmet between the CC_3 and CC_4 planes. The level of the CC_2 plane is marked on the back of the helmet behind the CC_4 plane. Finally, the segments of the CC_3 plane between the CC_0 and CC_1 planes and the segments of the CC_4 plane between the CC_1 and CC_2 planes shall be marked on the sides of the helmet.

These lines enclose a distinct area of the helmet and mark the boundary of the extent of protection. A test line shall be marked within this boundary so that it is 15 mm from the closest point on the

boundary as shown in figure 1a. If the boundary of the extent of protection falls below the edge of the helmet it need not be a cause for rejection. However, if, in the test technician's judgement, there is insufficient material in the helmet below the test line to withstand impact testing without endangering the test equipment, the helmet may be rejected at this point in the procedures.

PERIPHERAL VISION

The requirements and procedures set for peripheral vision in the base standards do not apply to helmets intended for children less than five years of age. Instead, the helmet will be placed on the appropriate headform and positioned according to the procedures for helmet marking.

The peripheral visual clearance, shown in figure 2a, is the solid angle bounded by the reference plane, the CC_2 plane and two more planes that are perpendicular to the reference plane and that contain the point on the front of the headform where the longitudinal and reference planes intersect. One of these two planes forms an angle of 110° with the longitudinal plane and lies to the left of the headform. The other forms the same angle to the right of the headform. No part of the helmet may intrude into this clearance.

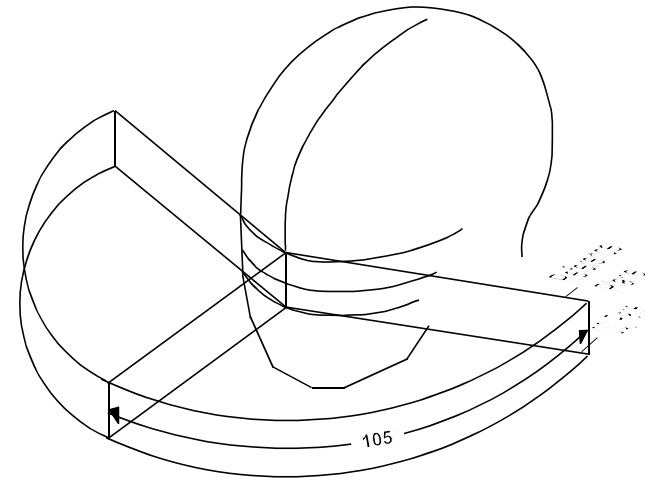

figure 2a - Peripheral Vision Child Helmet

Shortly after William "Pete" Snell died of massive head injuries received during an automotive racing accident, his friends and associates formed the Snell Memorial Foundation. The goals of the Foundation were to investigate and understand the mechanisms of head injury and to encourage the development of truly protective helmets for use in automotive sports.

The Snell Memorial Foundation is a not-for profit organization incorporated in 1957 under the laws of The State of California. It exists solely for the purpose of engaging in scientific and educational activities promoting the safety, well-being and comfort of persons engaged in any type of travel or vehicular transportation.

Today, the Snell Memorial Foundation tests various kinds of helmets and certifies them for use in prescribed activities. It currently publishes standards for protective headgear for use in automotive racing, karting, motorcycling, bicycling, non-motorized sports, harness racing and equestrian sports, competitive skiing and snowboarding. The Foundation is interested in just about every kind of headgear worn to protect against crash impact injury.

Helmet manufacturers submit their products for certification. If their helmets pass the demanding series of performance tests, and therefore meet the referenced standard, the manufacturers are invited to enter a contract with The Snell Memorial Foundation which entitles them to use the Snell Memorial Foundation name and logo in their packaging and advertising, and to purchase certification decals from The Foundation for use in their certified products. However, this contract also requires the certified manufacturers to maintain their high standards for all of their certified production and to participate in the random sample test program. In this program, the Foundation acquires and tests helmets to certify the continuing quality of the products. The Foundation takes pains to see that these random sample helmets are drawn from the same supply as those sold in stores; thus the Foundation is able to monitor the quality of the helmets sold directly to the consumer.

Participation in the Snell certification program is strictly voluntary. Manufacturers are not obliged to seek certification or to continue it, but while a manufacturer does participate, the Foundation demands full compliance. Similarly, the Foundation prosecutes all unauthorized use of the Snell name and logo to the full extent of the law.

The Snell Memorial Foundation maintains a state of the art testing facility in North Highlands, California. There is a Board of Directors who oversees the activities of the Foundation, and a salaried staff who conducts the testing and performs the administrative functions.

The Snell Memorial Foundation, Inc.
3628 Madison Avenue, Suite 11
North Highlands, California 95660
Tel. (916) 331-5073, Fax (916) 331-0359, E-mail
info@smf.org, WEB Address <http://www.smf.org>
© 2000 Snell Memorial Foundation, Inc.